

# Saramonic®

Compact Stereo Microphone  
for Android Devices with a  
USB Type-C Connector

SPMIC510 UC

User Manual

Thank you for choosing Saramonic!

Saramonic SPMIC510 UC is a compact stereo condenser microphone designed for smartphones, tablets and computers with a USB Type-C connector.

The microphone is equipped with two condenser microphone elements positioned in an X/Y configuration. It provides superb stereo sound that is ideal for vlogging, live streaming, interviews, ENG and mobile video production.

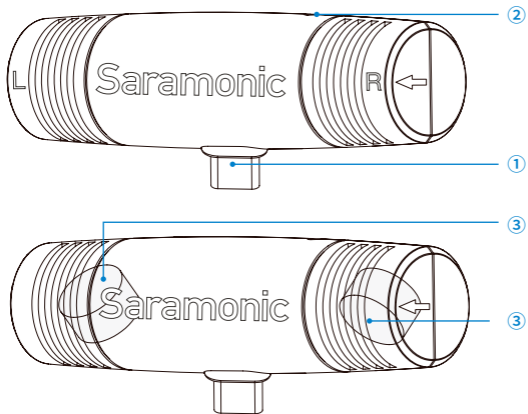

- ① USB Type-C connector
- ② LED power indicator
- ③ Microphone capsules

## Highlights

- Plug-and-play
- Dual Condenser Elements in X/Y Pattern
- Compact and lightweight design. Ideal when using with smartphone accessories, like gimbals
- For smartphones, tablets and computers with a USB Type-C connector

## Setup Guide

1. Plug the microphone directly into the USB Type-C connector of your device
2. For optimum signal, please make sure the arrow mark on the microphone is pointed at the sound source.
3. Download a recording APP, like Cinema FV-5. Open the APP and Camera, the microphone LED indicator will turn blue, then you are ready to record.

### **Note:**

1. To avoid any noise, please turn down the volume of your recording device and unplug the 3.5mm jack headphone (when using a Pad or PC).
2. Please make sure the OTG of your phone is on. If not, the microphone may not work.
3. For Samsung, Huawei, OPPO phones, the SPMIC510UC can not work without the APP

## Common Technical Issues and Solutions

- If you have any problems when using SPMIC510 UC, please refer to below list:

Issue	Reason	Solution
Mic is not recognized by recording device	Mic is not well connected	Unplug and reconnect
Mic is not picking up sound	1. Mic is not well connected 2. No recording APP	Plug out and try again, it works only after the blue indicator is on. Please make sure the recording APP is on.
No sound when you plug out and replug the mic during recording	You may use a 3.5mm headphone simultaneously	Plug out both the headphone and mic, and try again.
Sound is distorted	The input level of your device is too high	Lower the input level before recording
	You are monitoring with a mono headphone	Choose a stereo headphone
The mic is picking up too much ambient sound, not the subject	1. Recording distance is too far from subject 2. The mic's capsule are pointing in the wrong direction	1. Get closer to the subject. 2. Make sure the arrow mark on the mic points at the sound source

- If you have further questions, please consult your dealer or [info@saramonic.com](mailto:info@saramonic.com)

## Specifications

Transducer Type	Condenser
Polar Pattern	Cardioid (X/Y Pattern)
Audio	48 kHz / 16-bit
Frequency response	45 - 20,000 Hz
Signal to noise ratio	78dB
Output	USB Type-C Connector
Power	Powered by the connected device
Operating temperature	-10°C - 55 °C
Dimension (L x W x H)	70 x 18.4 x 26.88mm
Weight	15.5g (0.55oz.)



**[www.saramonic.com](http://www.saramonic.com)**

Saramonic is a trademark registered and owned by Shenzhen DSQN Investment CO., LTD.

COPYRIGHT 2011-2021 SARAMONIC INTERNATIONAL ( A brand of DSQN )

Room 2009, Shenzhou Bairuida Bldg, Banxuegang Road, Bantian Street, Longgang District,  
Shenzhen, China 518129 Email: [info@saramonic.com](mailto:info@saramonic.com)

**Made in China**