

1 Product Introduction

1.1 General Introductions

The Saramonic Vmic Pro Mark II is a supercardioid on-camera condenser shotgun microphone that provides broadcast-quality audio to DSLR, Mirrorless and Video Cameras. The Vmic Pro Mark II features an input level control (-10dB, 0dB, +20dB), a high-pass filter (150 Hz) and a high-frequency boost (+6dB) to increase intelligibility of dialogue. The detachable 3.5mm cable connects the Vmic Pro Mark II to your camera's audio input and the stereo headphone output allows you to monitor the incoming audio. The specially designed shock mount system provides isolation from vibration and mechanical noise.

1.2 Highlights

- Supercardioid polar pattern
- Integrated shock mount system
- High-pass filter (150 Hz)
- High-frequency boost (+6dB)
- Three-position level control (-10dB, 0dB, +20dB)
- Headphone monitor output
- 3.5mm audio output to camera
- Power/low battery indicator
- Foam windshield included
- Lightweight all-metal construction
- Powered by the 2 AA batteries

1.3 Product Structure

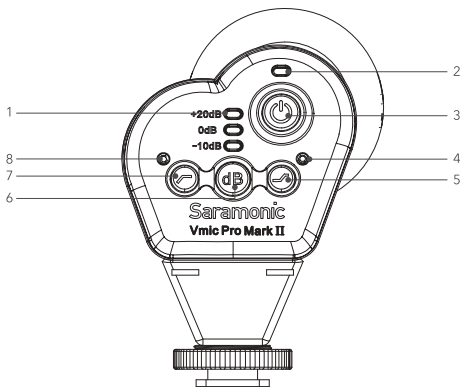

1. Level indicator (-10dB, 0dB, +20dB)
2. Power indicator
Green light=Power on
Red light=Low battery
3. Power button
4. High-frequency boost indicator
5. High-frequency boost button
6. Three-position level control button
7. High-pass filter button
To attenuate frequencies lower than 150 Hz.
It can be used to remove rumble or other low frequency noise while recording.
8. High-pass filter indicator

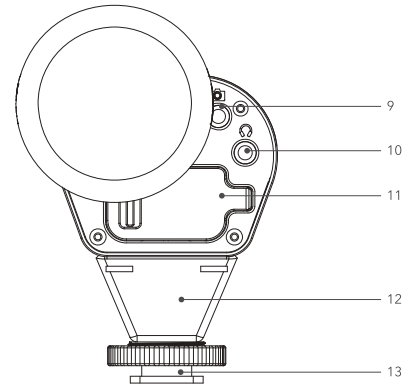

9. Microphone output jack
10. Headphone monitor output jack
11. Battery compartment
12. Integrated shock mount
13. Cold shoe mount

2 Set Up Guide

2.1 Install the battery

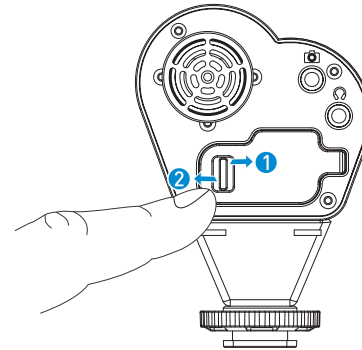

1. Unlock the battery compartment
Insert 2×AA battery into place aligning + and - polarity as shown.
2. Lock the battery compartment

2.2 Attach the Vmic Pro Mark II to your camera's shoe mount.

Connect the Vmic Pro Mark II's microphone output to the microphone input of the camera using the supplied 3.5mm audio output cable.

2.3 Turn on your camera and long press the power button to turn on the Vmic Pro Mark II, the indicator will turn green when on. When the battery power is low, the indicator will turn red.

2.4 Adjust the microphone's level control according to your needs. The 0dB is appropriate for most scenarios, -10dB level is ideal for recording loud sound sources or environments, +20dB lets you to turn down your camera's preamp in order to achieve an ultra-clean sound or for picking up subjects from further away in quiet environments.

2.5 If your camera lacks a headphone jack for real-time monitoring, plug headphones into the headphone output jack to monitor the audio. We also suggest to recording a sample take and playing back to check if the audio level it is acceptable before recording.

3. Specification

Type	Condenser Microphone
Polar Pattern	Supercardioid
Frequency Response	50Hz to 20kHz
Sensitivity	-38dB±2dB (0dB=1V/Pa,at 1KHz)
Signal to Noise Ratio	80dB
Output Impedance	200 Ohm or less
Power	Two AA batteries
Output	3.5mm TRS connector
Filter	High-pass filter (150Hz)
Dimensions (L*H*D)	255.0×69.4×98.9 mm
Net Weight	295g (10.41oz)

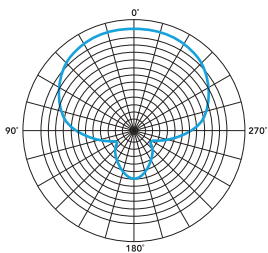
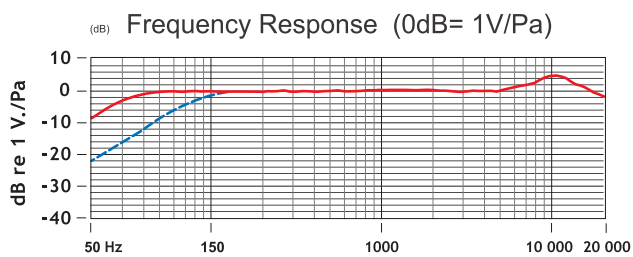

4. Packing List

- One Vmic Pro Mark II main unit
- One foam windshield
- One 3.5mm TRS audio output cable
- User manual
- Warranty card

JIAYZ 长丰 | 深圳市长丰影像器材有限公司

产品/零件名称	Vmic PRO Mark II说明书	比例	1 : 1	版本	V00
工程图号	Vmic PRO Mark II说明书	物料描述	105克哑粉 过油 三折页		
物料编号	1F0300400098	尺寸/用量	210x285mm 1PCS		
制图人/日期	贺磊/2019.7.25	正负公差	5mm		

受控文件

2019-7-30

长丰影像